

Figure 1 Model DF400 Control Valve and Actuator

The Model DF400 (Figure 1) is a heavy-duty eccentric plug control valve (sometimes referred to as a rotary globe valve) combined with a powerful spring-and-diaphragm actuator. This valve-actuator combo is used in all kinds of demanding applications, including oil and gas production, chemical process industries and severe service environments.

The self-aligning eccentric plug design and straight through flow pattern of the DF400 control valve provides tight shutoff while also allowing for higher flow capacities than other valves.

The exclusive low-profile actuator provides reduced deadband and hysteresis through a combination of low-friction design with a robust splined shaft connection. These actuators are spring-opposed rolling diaphragm style.

Model DF400 control valve/actuator assemblies are manufactured to a high level of quality ensuring superior performance and customer satisfaction.

Features

Sour Service Capability

Available in configurations that comply with NACE MR0175/ISO 15156 and NACE MR0103.

Compact Design

The smaller, lighter design of the DF400 control valve makes them easier to handle than standard globe valves of the same size, and usually half the weight.

Field Service Friendly

No special tools are required to inspect or service trim, and the actuator is field reversible without additional parts.

Versatile Trim Options

Metal and soft seat trim are available in a wide variety of reduced-port trim options.

Industrial High Quality External Coatings

Our standard industrial high quality external coatings provide long lasting resistance to the harshest environments.

Emissions Reducing Packing

Standard low-emission packing prevents the loss of process media and helps reduce packing maintenance.

Blowout Proof Shaft

DF400 shafts are made with a machined shoulder designed to provide exceptional blowout prevention.

Specifications

Configurations

The Model DF400 control valve is a high capacity single port, automatic-throttling, eccentric plug rotary valve. Refer to Table 1.

PTFE Seat and Metal Seat Available.

Consult your Dyna-Flo sales office for other available configurations.

Valve Sizes and Connection Styles (Refer to Table 1)

Model:	DF400
Size:	1" (25mm), 1-1/2" (40mm), 2" (50mm), 3" (80mm), 4" (100mm), 6" (150mm)
Body:	Cast with integral bonnet
Rating:	ASME 150 / 300 / 600
Connection:	RF - All Sizes Wafer - All Sizes

Maximum Inlet Pressures and Temperatures

Valves consistent with ASME Class 150, 300, and 600 rating as per ASME B16.34, unless limited.

Valve Assembly Temperature Limitations

Refer to Table 2 for process temperature limitations.

Refer to Tables 11 & 12 for limiting factors specific to valve part.

Ambient Actuator Temperature Limitation

-40°F to 180°F (-40°C to 82°C)

Characteristic and Flow Direction

Linear - Flow-to-Open or Flow-to-Close

Refer to Figure 3 for Flow Direction.

Cv Ratio

Standard Trim: >100:1

Reduced Port Trim: 15:1

Maximum Valve Sizing Coefficients

For maximum coefficients at maximum opening, refer to Table 5.

For all standard coefficients, refer to Tables 14 & 15.

Allowable Pressure Drops

Refer to Tables 16 to 19.

Dimensions

Valve and Actuator Outline Dimension Diagram: Refer to Figure 2.

Valve and Actuator Assembly Dimensions: Refer to Tables 7 to 9.

Materials

Body material options include:

WCC

CF3M

Refer to Table 11 for valve parts construction materials.

Refer to Tables 12 & 13 for trim selections.

Approximate Assembly Weights

Refer to Table 6.

Cross-Section of the Model DF400 Assembly

Refer to Figures 4 to 6.

Packing Type

The Standard packing is carbon core braided PTFE. Refer to Figures 4 & 6.

Valve Plug Travel Times and Actuator Size

Refer to Table 3.

Available Actuator Sizes

Refer to Table 1.

Actuator Tubing Connection Size

All sizes - 1/4 inch (6.35 mm) NPT.

Actuator Mounting Orientation

Refer to Figure 3.

For more information and other options contact your Dyna-Flo sales office.

Table 1

Available Valve and Actuator Configurations

Valve Model	Valve Size	End Connection				Actuator Size	Stroke	Operating Range
		Wafer	Raised Face (RF) Flanged					
		ASME Class 150-600	ASME Class 150	ASME Class 300	ASME Class 600			
DF400	1 inch NPS (25mm DN)	✓	✓	✓	✓	4-1/2 inch Diameter	3-1/2 inch (89 mm)	7 - 15 Psi (0.48 - 1.03 Bar)
	1-1/2 inch NPS (40mm DN)	✓	✓	✓	✓	4-1/2 inch Diameter	3-1/2 inch (89 mm)	
	2 inch NPS (50mm DN)	✓	✓	✓	✓	4-1/2 inch Diameter	3-1/2 inch (89 mm)	
	3 inch NPS (80mm DN)	✓	✓	✓	✓	6 inch Diameter	5-3/4 inch (146 mm)	
	4 inch NPS (100mm DN)	✓	✓	✓	✓	6 inch Diameter	5-3/4 inch (146 mm)	
	6 inch NPS (150mm DN)	✓	✓	✓	✓	7 inch Diameter	7-1/4 inch (178 mm)	7 - 24 Psi (0.48 - 1.65 Bar)

Table 2

Standard Shut-Off Classifications (in accordance with ANSI/FCI 70.2)
Process Temperature and Seat Leakage

Valve Size	Body Material	Seat Material	Temperature Range				Maximum Seat Leakage
			Minimum		Maximum		
			°F	°C	°F	°C	
All	WCC	Metal ⁽¹⁾	-20	-29	750	400	Class IV Shutoff
		PTFE (Soft) Seat ⁽¹⁾	-20	-29	450	232	Class VI Shutoff
	CF3M	Metal ⁽¹⁾	-325	-198	750	400	Class IV Shutoff
		PTFE (Soft) Seat ⁽¹⁾	-50	-46	450	232	Class VI Shutoff
Notes:	1 - For trim combination material options refer to Table 12. Temperature limitations for valves with Slurry Seal option may be determined by the Guide Bushing O-Ring, refer to Tables 11 & 12.						

Table 3

Standard Actuator Specifications and Stroke Times⁽¹⁾

Actuator Size Diameter		Effective Diaphragm Area		Actuator Stroke		Stroke Time (Seconds)	
Inch	mm	Sq. in	cm ²	Inch	cm	Increasing Instrument Signal	Decreasing Instrument Signal
4-1/2	114	14	90	3-1/2	8.9	1.2	2.4
6	152	24	155	5-3/4	14.6	3	6.3
7	178	36	232	7-1/4	18.4	7.6	9.8

Notes: 1 - Measured with direct positioner at 30 Psi (2 Bar) supply.

Table 4

Maximum Allowable Actuator Supply Pressure

Valve Size	Actuator Size	Maximum Supply Pressure	
		PSI	BAR
1" NPS (25mm DN)	4-1/2" (114mm)	20	1.38
1-1/2" NPS (40mm DN)	4-1/2" (114mm)	25	1.72
2" NPS (50mm DN)	4-1/2" (114mm)	30	2.07
3" NPS (80mm DN)	6" (152mm)	30	2.07
4" NPS (100mm DN)	6" (152mm)	45	3.10
6" NPS (150mm DN)	7" (178mm)	45	3.10

Table 5

Maximum Flow Coefficients (C_v) and Flow Factors (F_L) at 100 Percent Open (50°)

Valve Size	Factor	Flow-to-Open		Flow-to-Close	
		Rated C_v	F_L	Rated C_v	F_L
1 Inch NPS (25mm DN)	0.20	2.80	0.88	3	0.70
	0.40	5.60	0.88	6	0.70
	0.60	8.40	0.88	9	0.70
	1.00	14	0.85	15	0.68
1-1/2 Inch NPS (40mm DN)	0.40	13.2	0.88	15.6	0.70
	0.60	19.8	0.88	23.4	0.70
	1.00	33	0.85	39	0.68
2 Inch NPS (50mm DN)	0.40	20	0.88	21.2	0.70
	0.60	30	0.88	31.8	0.70
	1.00	50	0.85	53.0	0.68
3 Inch NPS (80mm DN)	0.40	54	0.88	58	0.70
	0.60	81	0.88	87	0.70
	1.00	135	0.85	145	0.68
4 Inch NPS (100mm DN)	0.40	92	0.88	92	0.70
	0.60	138	0.88	138	0.70
	1.00	230	0.85	230	0.68
6 Inch NPS (150mm DN)	0.40	200	0.88	200	0.70
	0.60	300	0.88	300	0.70
	1.00	500	0.85	500	0.68
Notes:	Refer to Tables 14 & 15 for full C_v list.				

Table 6

Approximate Valve/Actuator Assembly Weights

Valve Size	Actuator Size	Wafer Class 150-600		ASME Class 150		ASME Class 300		ASME Class 600	
		lbs.	Kg	lbs.	Kg	lbs.	Kg	lbs.	Kg
1 Inch (25mm)	4-1/2 Inch	38	17	40	18	44	20	44	20
1-1/2 Inch (40mm)	4-1/2 Inch	42	19	48	22	53	24	55	25
2 Inch (50mm)	4-1/2 Inch	44	20	53	24	60	27	62	28
3 Inch (80mm)	6 Inch	101	46	115	52	126	57	130	59
4 Inch (100mm)	6 Inch	119	54	143	65	161	73	183	83
6 Inch (150mm)	7 Inch	227	103	254	115	289	131	344	156

Table 7

Valve and Actuator Assembly Dimensions (Refer to Figure 2)

Valve Size	Dimensions - Inch								
	A	B	BW	C	D	E	F	G	H
1 Inch NPS	4.00	2.01	2.64	1.50	8.00	5.30	6.60	11.90	5.50
1-1/2 Inch NPS	4.50	2.31	2.44	2.00	9.10	6.40	6.60	11.90	5.50
2 Inch NPS	4.88	2.46	2.44	2.60	9.30	6.60	6.60	11.90	5.50
3 Inch NPS	6.50	3.39	3.82	3.30	12.90	9.40	9.80	17.20	6.90
4 Inch NPS	7.62	4.17	4.17	4.30	13.70	10.30	9.80	17.20	6.90
6 Inch NPS	9.00	5.00	5.00	5.80	16.90	12.60	12.30	20.80	8.60

Valve Size	Dimensions - mm								
	A	B	BW	C	D	E	F	G	H
25mm DN	102	51	67	38	204	134	168	302	140
(40mm DN)	114	59	62	51	232	162	168	302	140
50mm DN	124	63	62	65	237	167	168	302	140
80mm DN	165	86	97	84	327	239	249	436	175
100mm DN	194	106	106	108	349	262	249	436	175
150mm DN	229	127	127	146	429	320	313	527	219

Table 8

Handwheel Dimensions (Refer to Figure 2)

Valve Size	L		M	
	Inch	mm	Inch	mm
1 Inch NPS (25mm DN)	10.10	257	6.30	160
1-1/2 Inch NPS (40mm DN)	10.10	257	6.30	160
2 Inch NPS (50mm DN)	10.10	257	6.30	160
3 Inch NPS (80mm DN)	10.60	269	6.30	160
4 Inch NPS (100mm DN)	10.60	269	6.30	160
6 Inch NPS (150mm DN)	12.10	307	10.0	160

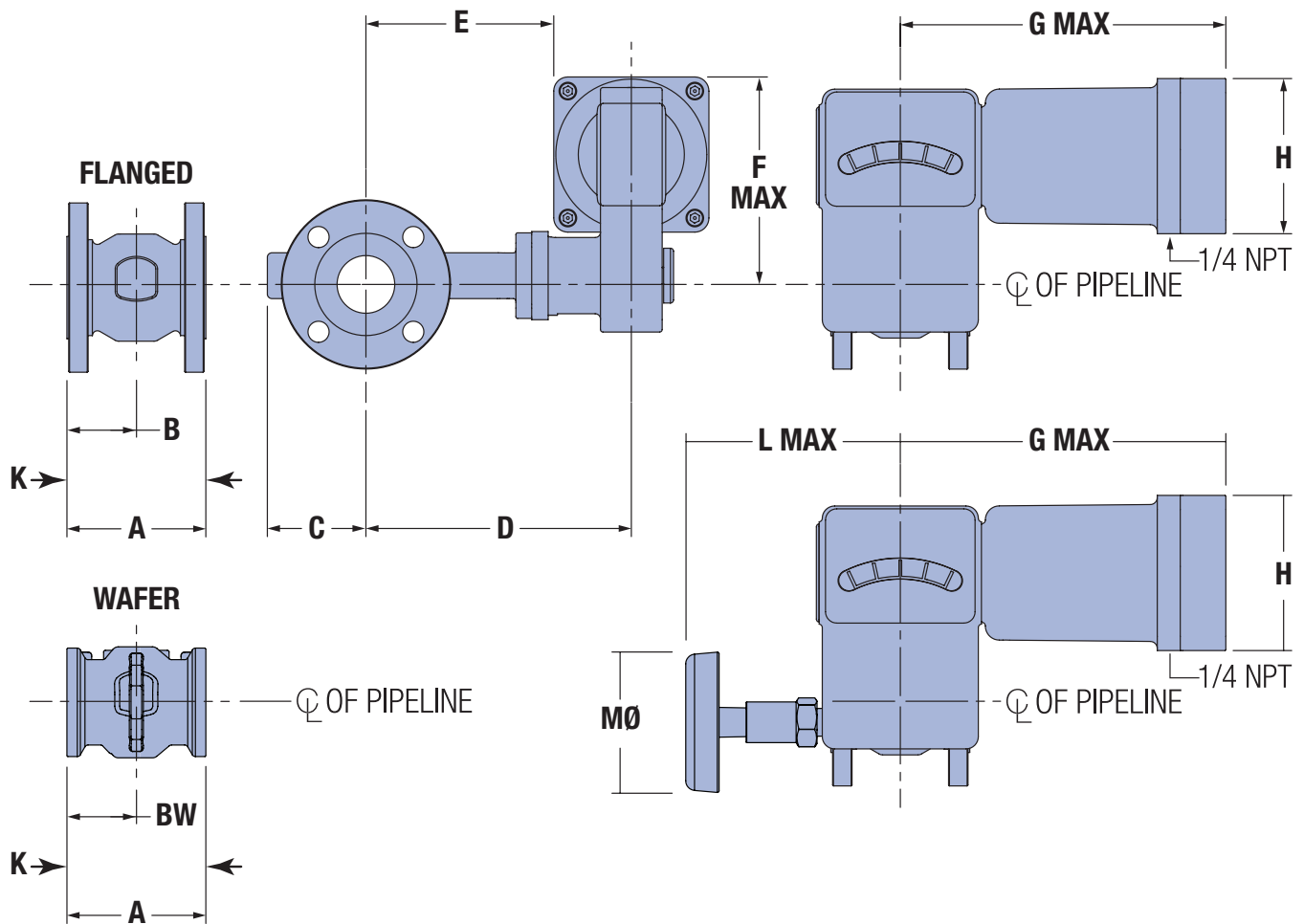
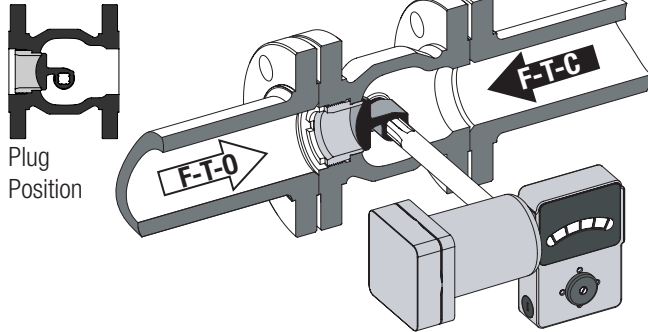

Figure 2 Typical Valve and Actuator Assembly Dimensional Diagram

Table 9						
Flange Bolt Clearance Dimensions (Refer to Figure 2)						
Valve Size	K					
	ASME Class 150 PN 10		ASME Class 300 PN 16		ASME Class 600 PN 40	
	Inch	mm	Inch	mm	Inch	mm
1 Inch NPS (25mm DN)	6.50	205	9.00	229	9.00	229
1-1/2 Inch NPS (40mm DN)	6.50	205	10.00	254	10.00	254
2 Inch NPS (50mm DN)	10.50	267	10.50	267	10.50	267
3 Inch NPS (80mm DN)	11.80	300	13.50	343	14.00	356
4 Inch NPS (100mm DN)	13.00	330	14.00	356	16.50	406
6 Inch NPS (150mm DN)	15.50	394	16.00	406	18.50	470

Air-to-Open Configurations

Actuator Position 2



Actuator Position 4

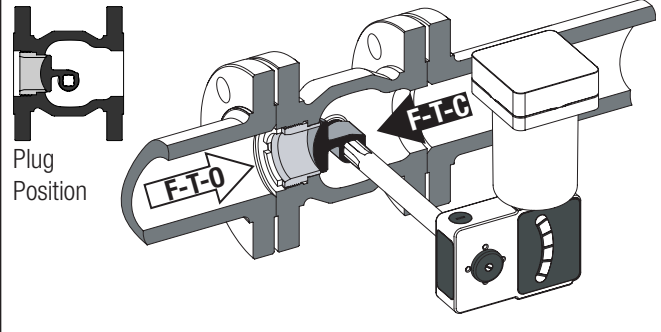

Actuator Position 8

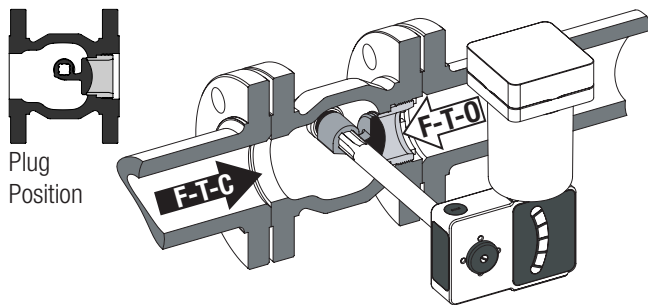

Actuator Position 6

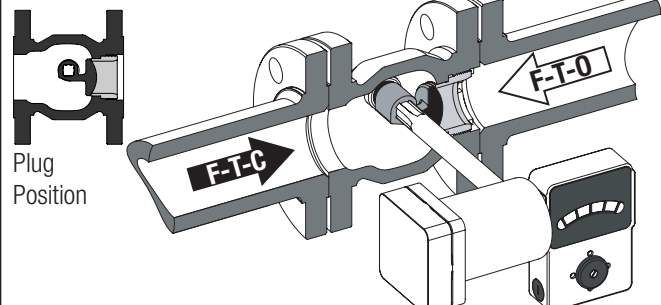

Air-to-Close Configurations

Actuator Position 3

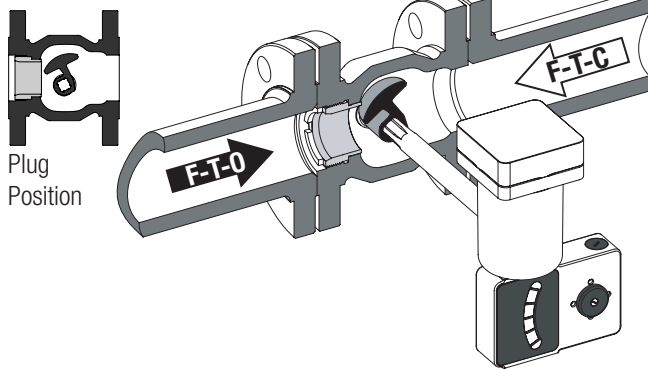

Actuator Position 1

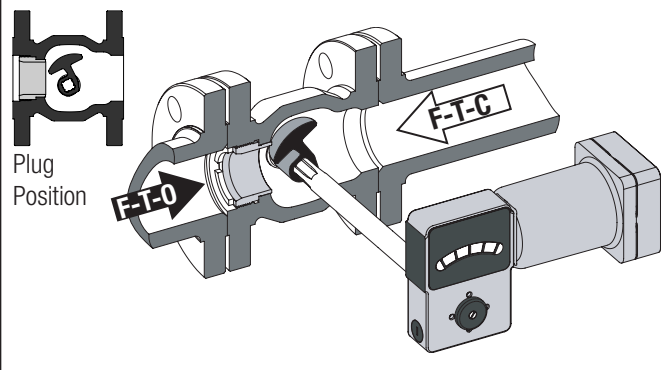

Actuator Position 5

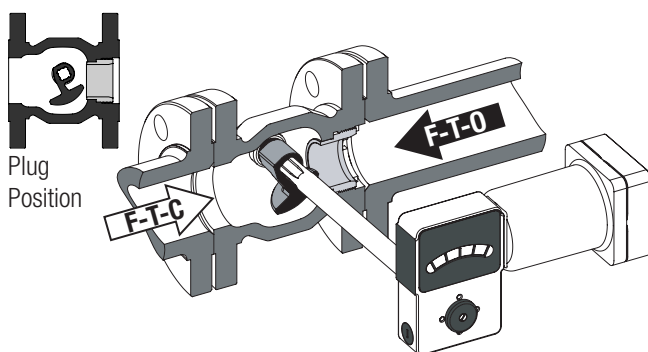

Actuator Position 7

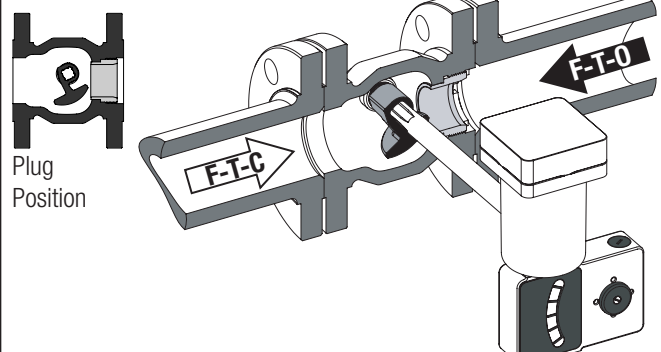

Figure 3 Actuator Mounting Positions in Relation to Valve Body (Refer to Table 10 on Page 9 for Notes)

Figure 3 - Actuator Mounting Positions Notes

- Grey shaded actuators represent standard actuator mounting positions.
- Black arrows represent the recommended flow direction. F-T-C = Flow-to-Close F-T-O = Flow-to-Open
- Installation of valve and actuator is assumed and recommended to be in the horizontal position (parallel to the ground). Consult Dyna-Flo regarding installation of the assembly into positions other than horizontal.
- Valve plug positions are shown in their starting positions (position without air applied to the actuator).
- Operating efficiencies may vary depending on valve/actuator orientation and configuration.

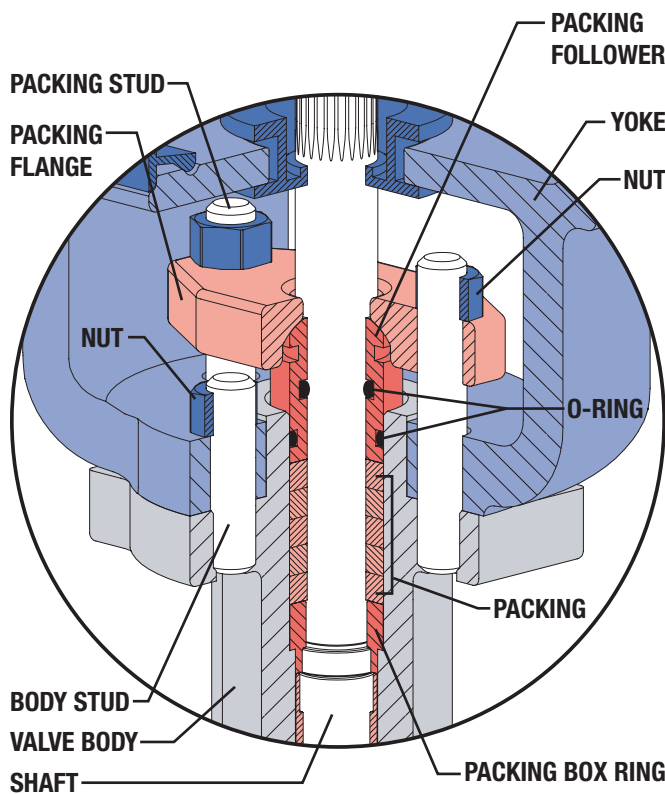

Figure 4 Standard Valve Packing Detail

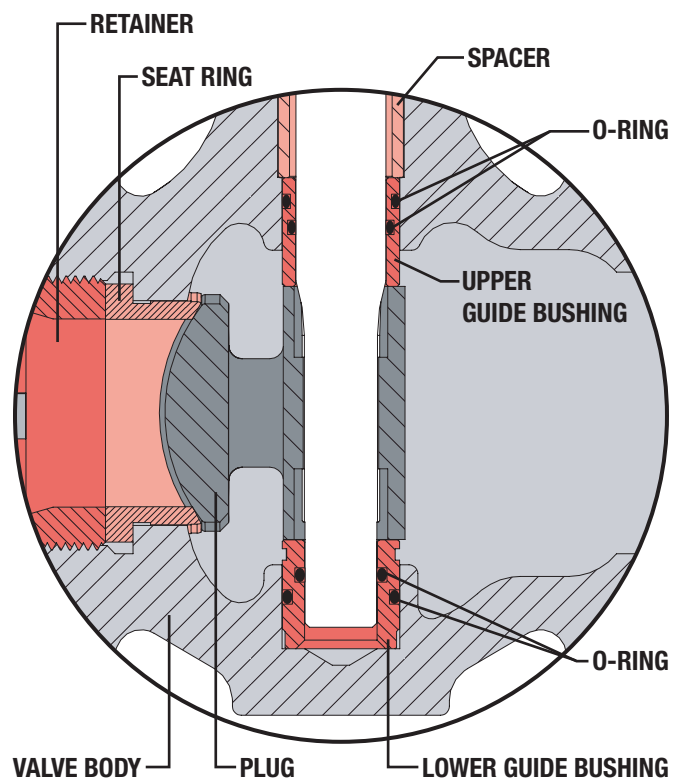

Figure 5 Slurry Trim Package Detail

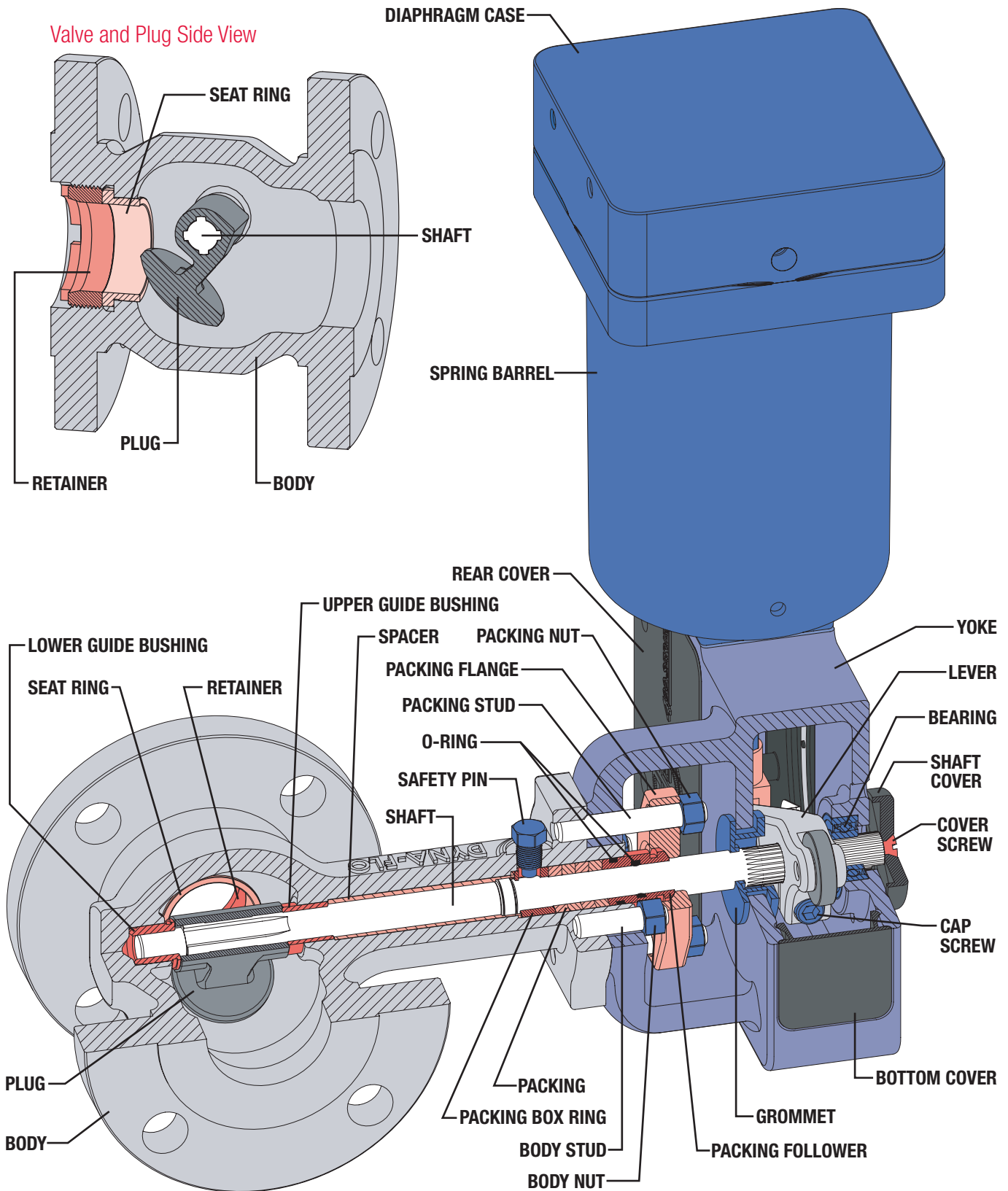

Figure 6 Model DF400 Valve and Actuator Cross Section

Table 11

Common Parts Typical Construction Materials and Temperature Limitations

Part	Material	Temperature Limitations				
		Min. °F	Max. °F	Min. °C	Max. °C	
Body Nut	ASTM A194 Grade 8	NLF ⁽¹⁾	NLF ⁽¹⁾	NLF ⁽¹⁾	NLF ⁽¹⁾	
Body Stud	ASTM A193 B8	NLF ⁽¹⁾	NLF ⁽¹⁾	NLF ⁽¹⁾	NLF ⁽¹⁾	
Packing	Carbon Core Braided PTFE	NLF ⁽¹⁾	NLF ⁽¹⁾	NLF ⁽¹⁾	NLF ⁽¹⁾	
Packing Box Ring	S31600/S31603 Dual Grade	NLF ⁽¹⁾	NLF ⁽¹⁾	NLF ⁽¹⁾	NLF ⁽¹⁾	
Packing Flange	Zinc Plated Steel	NLF ⁽¹⁾	NLF ⁽¹⁾	NLF ⁽¹⁾	NLF ⁽¹⁾	
Packing Follower	S31600/S31603 Dual Grade	NLF ⁽¹⁾	NLF ⁽¹⁾	NLF ⁽¹⁾	NLF ⁽¹⁾	
Packing Follower O-Rings	Standard	VITON	NLF ⁽¹⁾	400	NLF ⁽¹⁾	205
	NACE	KALREZ®	-5.8	482	-21	250
Packing Nuts	ASTM A193 B8	NLF ⁽¹⁾	NLF ⁽¹⁾	NLF ⁽¹⁾	NLF ⁽¹⁾	
Packing Studs	ASTM A194 Grade 8	NLF ⁽¹⁾	NLF ⁽¹⁾	NLF ⁽¹⁾	NLF ⁽¹⁾	
Plug	Refer to Table 12	NLF ⁽¹⁾	NLF ⁽¹⁾	NLF ⁽¹⁾	NLF ⁽¹⁾	
Plug Retainer	Refer to Table 12	NLF ⁽¹⁾	NLF ⁽¹⁾	NLF ⁽¹⁾	NLF ⁽¹⁾	
Safety Pin	S31600/S31603 Dual Grade	NLF ⁽¹⁾	NLF ⁽¹⁾	NLF ⁽¹⁾	NLF ⁽¹⁾	
Seat Ring	Refer to Table 12	NLF ⁽¹⁾	NLF ⁽¹⁾	NLF ⁽¹⁾	NLF ⁽¹⁾	
Spacer	S31600/S31603 Dual Grade	NLF ⁽¹⁾	NLF ⁽¹⁾	NLF ⁽¹⁾	NLF ⁽¹⁾	
Valve Shaft	S20910	NLF ⁽¹⁾	NLF ⁽¹⁾	NLF ⁽¹⁾	NLF ⁽¹⁾	
Upper Guide Bushing	Standard	S44004	NLF ⁽¹⁾	NLF ⁽¹⁾	NLF ⁽¹⁾	NLF ⁽¹⁾
	NACE	R30006	NLF ⁽¹⁾	NLF ⁽¹⁾	NLF ⁽¹⁾	NLF ⁽¹⁾
Lower Guide Bushing	Standard	S44004	NLF ⁽¹⁾	NLF ⁽¹⁾	NLF ⁽¹⁾	NLF ⁽¹⁾
	NACE	R30006	NLF ⁽¹⁾	NLF ⁽¹⁾	NLF ⁽¹⁾	NLF ⁽¹⁾
Guide Bushing O-Rings (Slurry Seal Option Only)	Standard	VITON	NLF ⁽¹⁾	400	NLF ⁽¹⁾	205
	NACE	KALREZ®	NLF ⁽¹⁾	600	NLF ⁽¹⁾	316

Notes: 1 - NLF - This Material is Not A Limiting Factor. For the standard valve assembly temperature limitations refer to Table 2. For valve trim specific temperature limitations refer to Table 12.

Table 12

Standard Valve Trim Options and Temperature Limitations⁽³⁾

Trim Designation	Plug	Seat Ring	Retainer	Temperature Limitation			
				Min. °F	Max. °F	Min. °C	Max. °C
A	R30006	S31600/S31603 ⁽¹⁾	S31600/S31603 ⁽¹⁾	NLF ⁽²⁾	NLF ⁽²⁾	NLF ⁽²⁾	NLF ⁽²⁾
B	R30006	R30006	S31600/S31603 ⁽¹⁾	NLF ⁽²⁾	NLF ⁽²⁾	NLF ⁽²⁾	NLF ⁽²⁾
C	R30006	S31600 ⁽¹⁾ /PTFE	S31600/S31603 ⁽¹⁾	-50	450	-46	232
D	R30006	R30006	R30006	NLF ⁽²⁾	NLF ⁽²⁾	NLF ⁽²⁾	NLF ⁽²⁾
E	S31603/CoCr-A Hard Faced Seat	S31600/S31603 ⁽¹⁾	S31600/S31603 ⁽¹⁾	NLF ⁽²⁾	NLF ⁽²⁾	NLF ⁽²⁾	NLF ⁽²⁾
F	S31603/CoCr-A Hard Faced Seat	S31600 ⁽¹⁾ /CoCr-A Hard Faced Seat & Bore	S31600/S31603 ⁽¹⁾	NLF ⁽²⁾	NLF ⁽²⁾	NLF ⁽²⁾	NLF ⁽²⁾
G	S31603/CoCr-A Hard Faced Seat	S31600 ⁽¹⁾ /PTFE	S31600/S31603 ⁽¹⁾	-50	450	-46	232
H	S31603/CoCr-A Hard Faced Seat	R30006	R30006	NLF ⁽²⁾	NLF ⁽²⁾	NLF ⁽²⁾	NLF ⁽²⁾
Notes:	1 - All S31600 barstock is dual grade S31600/S31603 (316/316L).						
	2 - NLF - This Material is Not A Limiting Factor. Refer to Table 2 and Table 11 for other limiting factors.						
	3 - Temperature limitations for valves with Slurry Seal option may be determined by the Guide Bushing O-Ring, refer to Table 11.						

Table 13

Available Valve Size and Trim Combinations

Valve Size	Factor	Available Trim Set
1 Inch NPS (25mm DN)	0.20	A, B
	0.40	A, B, C, D
	0.60	
	1	
1-1/2 Inch NPS (40mm DN)	0.40	A, B, C, D
	0.60	
	1.00	
2 Inch NPS (50mm DN)	0.40	A, B, C, D
	0.60	
	1.00	
3 Inch NPS (80mm DN)	0.40	E, F, G, H
	0.60	
	1.00	
4 Inch NPS (100mm DN)	0.40	E, F, G, H
	0.60	
	1.00	
6 Inch NPS (150mm DN)	0.40	E, F, G, H
	0.60	
	1.00	

Table 14

Flow Coefficients (C_v) and Flow Factors (F_L) and Travel Relation (Flow-to-Open)

Percentage of Plug Rotation						10	20	30	40	50	60	70	80	90	100
F_L Full Area						0.96	0.93	0.91	0.89	0.88	0.87	0.87	0.86	0.86	0.85
F_L Reduced Area (0.2, 0.4, 0.6)						0.96	0.93	0.91	0.89	0.88	0.88	0.88	0.88	0.88	0.88
Valve Size	Factor	Port Diameter		Actuator Stem Travel		Rated CV at Percentage of Plug Rotation									
		Inch	mm	Inch	mm	10	20	30	40	50	60	70	80	90	100
1 Inch NPS (25mm DN)	0.20	0.321	8.2	3.50	89	0.4	0.8	1.1	1.4	1.7	2.0	2.3	2.5	2.7	2.8
	0.40	0.500	12.7	3.50	89	0.5	0.9	1.4	2.0	2.7	3.5	4.2	4.8	5.2	5.6
	0.60	0.579	14.7	3.50	89	0.6	1.3	2.2	3.1	4.2	5.3	6.4	7.2	7.9	8.4
	1	0.718	18.2	3.50	89	0.9	2.1	3.7	5.7	7.8	9.6	11.1	12.4	13.3	14
1-1/2 Inch NPS (40mm DN)	0.40	0.750	19.1	3.50	89	1.1	2.1	3.3	4.7	6.5	8.4	9.9	11.2	12.3	13.2
	0.60	0.907	23.0	3.50	89	1.4	3.2	5.1	7.4	10	12.7	15	17.1	18.6	19.8
	1	1.125	28.5	3.50	89	2.0	5.0	8.6	13	19	22	26	29	32	33
2 Inch NPS (50mm DN)	0.40	1.000	25.4	3.50	89	1.6	3.2	5.0	7.2	9.8	12.6	15.0	17.0	18.7	20
	0.60	1.159	29.4	3.50	89	2.1	4.8	7.7	11.2	15.1	19.1	22.7	25.8	28.2	30
	1	1.437	36.5	3.50	89	3.1	7.5	13.3	20.5	28	34.2	39.8	44.2	47.5	50
3 Inch NPS (80mm DN)	0.40	1.500	38.1	5.75	146	4.9	9.4	14.1	20	26.5	33.5	39.8	45.4	50.2	54
	0.60	1.874	47.6	5.75	146	5.7	12.1	19.6	27.6	37.5	47.9	58.4	68.0	75.9	81
	1	2.324	59.0	5.75	146	8.8	17.7	29.8	44.5	60.7	78.3	96.2	113	127	135
4 Inch NPS (100mm DN)	0.40	2.000	50.8	5.75	146	8.4	16.1	24.0	34.1	45.1	57.1	67.8	77.4	85.6	92
	0.60	2.419	61.4	5.75	146	9.7	20.7	33.4	47	63.8	81.6	99.4	116	129	138
	1	3.000	76.2	5.75	146	15.0	30.2	50.8	75.8	104	133	164	193	216	230
6 Inch NPS (150mm DN)	0.40	3.000	76.2	7.25	184	18.2	34.9	52.2	74.1	98	124	147	168	186	200
	0.60	3.629	92.2	7.25	184	21.2	44.9	72.7	102	139	177	216	252	281	300
	1	4.500	114	7.25	184	32.7	65.7	110	165	225	290	356	419	470	500

Table 15

Flow Coefficients (C_v) and Flow Factors (F_L) and Travel Relation (Flow-to-Close)

		Percentage of Plug Rotation													
		10	20	30	40	50	60	70	80	90	100				
F_L Full Area		0.94	0.91	0.88	0.83	0.80	0.77	0.74	0.72	0.70	0.68				
F_L Reduced Area (0.2 , 0.4 , 0.6)		0.94	0.91	0.88	0.83	0.80	0.77	0.74	0.72	0.70	0.70				
Valve Size	Factor	Port Diameter		Actuator Stem Travel		Rated CV at Percentage of Plug Rotation									
		Inch	mm	Inch	mm	10	20	30	40	50	60	70	80	90	100
1 Inch NPS (25mm DN)	0.20	0.321	8.2	3.50	89	0.4	0.9	1.2	1.5	1.8	2.1	2.5	2.7	2.9	3.0
	0.40	0.500	12.7	3.50	89	0.5	1.0	1.5	2.1	2.9	3.8	4.5	5.1	5.6	6.0
	0.60	0.579	14.7	3.50	89	0.6	1.4	2.4	3.3	4.5	5.7	6.9	7.7	8.5	9.0
	1	0.718	18.2	3.50	89	1.0	2.3	4.0	6.1	8.4	10.3	11.9	13.3	14.3	15.0
1-1/2 Inch NPS (40mm DN)	0.40	0.750	19.1	3.50	89	1.3	2.5	3.9	5.6	7.7	9.9	11.7	13.2	14.5	15.6
	0.60	0.907	23.0	3.50	89	1.7	3.8	6.0	8.7	11.8	15.0	17.7	20.2	22.0	23.4
	1	1.125	28.5	3.50	89	2.4	5.9	10.2	15.4	22.5	26.0	30.7	34.3	37.8	39.0
2 Inch NPS (50mm DN)	0.40	1.000	25.4	3.50	89	1.7	3.4	5.3	7.6	10.4	13.4	15.9	18.0	19.8	21.2
	0.60	1.159	29.4	3.50	89	2.2	5.1	8.2	11.9	16.0	20.2	24.1	27.3	29.9	31.8
	1	1.437	36.5	3.50	89	3.3	8.0	14.1	21.7	29.7	36.3	42.2	46.9	50.4	53.0
3 Inch NPS (80mm DN)	0.40	1.500	38.1	5.75	146	5.3	10.1	15.1	21.5	28.5	36.0	42.7	48.8	53.9	58.0
	0.60	1.874	47.6	5.75	146	6.1	13.0	21.1	29.6	40.3	51.4	62.7	73.0	81.5	87.0
	1	2.324	59.0	5.75	146	9.5	19.0	32.0	47.8	65.2	84.1	103	121	136	145
4 Inch NPS (100mm DN)	0.40	2.000	50.8	5.75	146	8.4	16.1	24.0	34.1	45.1	57.1	67.8	77.4	85.6	92.0
	0.60	2.419	61.4	5.75	146	9.7	20.7	33.4	47.0	63.8	81.6	99.4	116	129	138
	1	3.000	76.2	5.75	146	15.0	30.2	50.8	75.8	104	133	164	193	216	230
6 Inch NPS (150mm DN)	0.40	3.000	76.2	7.25	184	18.2	34.9	52.2	74.1	98.0	124	147	168	186	200
	0.60	3.629	92.2	7.25	184	21.2	44.9	72.7	102	139	177	216	252	281	300
	1	4.500	114	7.25	184	32.7	65.7	110	165	225	290	356	419	470	500

Table 16

Allowable Pressure Drops - Metal Seat - Actuator Operating Range 7-15 Psi (0.48-1.03 Bar)

Valve Size	Port Diameter		Air-to-Close Flow-to-Close Supply = 20 Psig (1.38 Barg)		Air-to-Open Flow-to-Open Supply = 20 Psig (1.38 Barg)		Air-to-Close / Flow-to-Open & Air-to-Open / Flow-to-Close Supply Pressure - Psi (Bar)					
	Inch	mm	Psig	Barg	Psig	Barg	20 Psig (1.38 Barg)	25 Psig (1.72 Barg)	30 Psig (2.07 Barg)	35 Psig (2.41 Barg)	40 Psig (2.76 Barg)	45 Psig (3.10 Barg)
1 Inch NPS (25mm DN)	0.718	18.2	1,000	69.0	1,000	69.0	1,000 (69.0)	---	---	---	---	---
	0.579	14.7	1,450	100	1,450	100	1,450 (100)	---	---	---	---	---
	0.500	12.7	1,450	100	1,450	100	1,450 (100)	---	---	---	---	---
	0.321	8.2	1,450	100	1,450	100	1,450 (100)	---	---	---	---	---
1-1/2 Inch NPS (40mm DN)	1.125	28.5	490	33.8	670	46.2	430 (29.7)	800 (55.2)	---	---	---	---
	0.907	23.0	740	51.0	1,000	69.0	640 (44.1)	1,375 (94.8)	---	---	---	---
	0.750	19.1	1,000	69.0	1,400	96.5	900 (62.1)	1,450 (100)	---	---	---	---
2 Inch NPS (50mm DN)	1.437	36.5	270	18.6	360	24.8	230 (15.9)	500 (34.5)	600 (41.4)	---	---	---
	1.159	29.4	410	28.3	560	38.6	350 (24.1)	760 (52.4)	1,000 (69.0)	---	---	---
	1.000	25.4	540	37.2	740	51.0	470 (32.4)	1,000 (69.0)	1,000 (69.0)	---	---	---
3 Inch NPS (80mm DN)	2.324	59.0	200	13.8	280	19.3	180 (12.4)	380 (26.2)	600 (41.4)	---	---	---
	1.874	47.6	320	22.1	420	29.0	270 (18.6)	580 (40.0)	930 (64.1)	---	---	---
	1.500	38.1	460	31.7	640	44.1	400 (27.6)	870 (60.0)	1,000 (69.0)	---	---	---
4 Inch NPS (100mm DN)	3.000	76.2	100	6.90	140	9.65	90 (6.21)	200 (13.8)	320 (22.1)	440 (30.3)	560 (38.6)	600 (41.4)
	2.419	61.4	160	11.0	220	15.2	140 (9.65)	300 (20.7)	490 (33.8)	670 (46.2)	860 (59.3)	1,000 (69.0)
	2.000	50.8	230	15.9	310	21.4	200 (13.8)	430 (29.7)	700 (48.3)	970 (66.9)	1,000 (69.0)	1,000 (69.0)

Table 17

**Allowable Pressure Drops - 6 inch NPS (150mm DN) Valve Body - Metal Seat
Actuator Operating Range 7-24 Psi (0.48-1.65 Bar)**

Port Diameter		Flow Direction	Air-to-Close Flow-to-Close Supply = 30 Psig (2.07 Barg)		Air-to-Open Flow-to-Open Supply = 30 Psig (2.07 Barg)		Air-to-Close / Flow-to-Open & Air-to-Open / Flow-to-Close Supply Pressure - Psig (Barg)				
			Psig	Barg	Psig	Barg	30 (2.07)	35 (2.41)	40 (2.76)	45 (3.10)	
Inch	mm										
4.5	114	FTO ⁽¹⁾	---	---	90	6.21	50 (3.45)	130 (8.96)	200 (13.8)	300 (20.7)	
		FTC ⁽²⁾ Gas	140	9.65	---	---	50 (3.45)	130 (8.96)	200 (13.8)	300 (20.7)	
		FTC ⁽²⁾ Liquid	140	9.65	---	---	50 (3.45)	130 (8.96)	200 (13.8)	300 (20.7)	
3.629	92.2	FTO ⁽¹⁾	---	---	131	9.03	70 (4.83)	180 (12.4)	300 (20.7)	400 (27.6)	
		FTC ⁽²⁾ Gas	220	15.2	---	---	70 (4.83)	180 (12.4)	300 (20.7)	400 (27.6)	
		FTC ⁽²⁾ Liquid	220	15.2	---	---	70 (4.83)	180 (12.4)	300 (20.7)	400 (27.6)	
3	76.2	FTO ⁽¹⁾	---	---	200	13.8	110 (7.58)	280 (19.3)	450 (31.0)	620 (42.7)	
		FTC ⁽²⁾ Gas	310	21.4	---	---	110 (7.58)	280 (19.3)	450 (31.0)	620 (42.7)	
		FTC ⁽²⁾ Liquid	310	21.4	---	---	110 (7.58)	280 (19.3)	450 (31.0)	500 (34.5)	
Notes:		1 - FTO = Flow-to-Open. 2 - FTC = Flow-to-Close.									

Table 18

Allowable Pressure Drops - PTFE (Soft) Seat - Actuator Operating Range 7-15 Psi (0.48-1.03 Bar)

Valve Size	Port Diameter		Air-to-Open Flow-to-Open Supply = 20 Psig (1.38 Barg)		Air-to-Close / Flow-to-Open & Air-to-Open / Flow-to-Close Supply Pressure - Psi (Bar)					
	Inch	mm	Psi	Bar	20 Psig (1.38 Barg)	25 Psig (1.72 Barg)	30 Psig (2.07 Barg)	35 Psig (2.41 Barg)	40 Psig (2.76 Barg)	45 Psig (3.10 Barg)
1 Inch NPS (25mm DN)	0.718	18.2	800	55.2	800 (55.2)	---	---	---	---	---
	0.579	14.7	1,000	69.0	1,000 (68.9)	---	---	---	---	---
	0.500	12.7	1,000	69.0	1,000 (68.9)	---	---	---	---	---
1-1/2 Inch NPS (40mm DN)	1.125	28.5	500	34.5	230 (15.9)	700 (48.3)	---	---	---	---
	0.907	23.0	1,000	69.0	320 (22.1)	1,000 (68.9)	---	---	---	---
	0.750	19.1	1,000	69.0	520 (35.6)	1,000 (68.9)	---	---	---	---
2 Inch NPS (50mm DN)	1.437	36.5	250	17.2	95 (6.55)	370 (25.5)	600 (41.4)	---	---	---
	1.159	29.4	530	36.5	140 (9.65)	530 (36.5)	940 (64.8)	---	---	---
	1.000	25.4	520	35.9	230 (15.9)	750 (51.7)	1,000 (68.9)	---	---	---
3 Inch NPS (80mm DN)	2.324	59.0	200	13.8	90 (6.21)	300 (20.7)	500 (34.5)	---	---	---
	1.874	47.6	420	29.0	130 (8.96)	420 (29.0)	740 (51.0)	---	---	---
	1.500	38.1	480	33.1	230 (15.9)	680 (46.9)	800 (55.2)	---	---	---
4 Inch NPS (100mm DN)	3.000	76.2	100	6.89	35 (2.41)	150 (10.3)	260 (17.9)	370 (25.5)	480 (33.1)	500 (34.5)
	2.419	61.4	210	14.5	50 (3.45)	210 (14.5)	380 (26.2)	540 (37.2)	710 (49.0)	800 (55.2)
	2.000	50.8	230	15.6	100 (6.89)	330 (22.8)	570 (39.3)	800 (55.2)	800 (55.2)	800 (55.2)

Table 19

**Allowable Pressure Drops - 6 inch NPS (150mm DN) Valve Body - PTFE (Soft) Seat
Actuator Operating Range 7-24 Psi (0.48-1.65 Bar)**

Port Diameter		Flow Direction	Air-to-Open Flow-to-Open Supply = 30 Psig (2.07 Barg)		Air-to-Close / Flow-to-Open & Air-to-Open / Flow-to-Close Supply Pressure - Psig (Barg)			
			Psig	Barg	30 (2.07)	35 (2.41)	40 (2.76)	45 (3.10)
Inch	mm							
4.5	114	FTO ⁽¹⁾	60	4.17	20 (1.38)	90 (6.21)	170 (11.7)	240 (16.5)
		FTC ⁽²⁾ Gas	---	---	20 (1.38)	90 (6.21)	170 (11.7)	240 (16.5)
		FTC ⁽²⁾ Liquid	---	---	20 (1.38)	90 (6.21)	170 (11.7)	240 (16.5)
3.629	92.2	FTO ⁽¹⁾	130	8.96	30 (2.07)	130 (8.96)	240 (16.6)	350 (24.1)
		FTC ⁽²⁾ Gas	---	---	30 (2.07)	130 (8.96)	240 (16.6)	350 (24.1)
		FTC ⁽²⁾ Liquid	---	---	30 (2.07)	130 (8.96)	240 (16.6)	350 (24.1)
3	76.2	FTO ⁽¹⁾	150	10.34	60 (4.14)	220 (15.2)	380 (26.2)	530 (36.5)
		FTC ⁽²⁾ Gas	---	---	60 (4.14)	220 (15.2)	380 (26.2)	530 (36.5)
		FTC ⁽²⁾ Liquid	---	---	60 (4.14)	220 (15.2)	380 (26.2)	500 (34.5)
Notes:		1 - FTO = Flow-to-Open. 2 - FTC = Flow-to-Close.						

DF400 ACTUATOR NUMBERING SYSTEM

SAMPLE PART NUMBER: **DF400A - C - 4 2 - 1 - N 1**

FAIL POSITION						C	
C	CLOSED (AIR TO OPEN)	0	OPEN (AIR TO CLOSE)				
ACTUATOR SIZE						4	
4	4-1/2" (114MM)	6	6" (152MM)	7	7" (178MM)		
VALVE SIZE NPS(DN)						2	
1	1 INCH (25MM)	5	1-1/2 INCH (40MM)	2	2 INCH (50MM)		3
4	4 INCH (100MM)	6	6 INCH (150MM)				
SPRING RANGE						1	
1	7-15 PSIG (0.48-1.03 BARG)			2	7-24 PSIG (0.48-1.65 BARG)		
PAINT						-	
-	DFPS-01 (STANDARD)			2	DFPS-02 (SEVERE SERVICE)		
3	DFPS-03 (HIGH TEMPERATURE)						
HANDWHEEL						N	
N	NONE	H	HANDWHEEL				
MOUNTING POSITION (REFER TO PAGE 6)						1	
1	POSITION 1	2	POSITION 2	3	POSITION 3		4
5	POSITION 5	6	POSITION 6	7	POSITION 7	8	POSITION 8

DF400A - - - - -

DF400 VALVE NUMBERING SYSTEM

SAMPLE PART NUMBER: DF400V - 1 A F L - A C - V F 1

VALVE SIZE NPS(DN)						1		
1	1 INCH (25MM)	5	1-1/2 INCH (40MM)	2	2 INCH (50MM)		3	3 INCH (80MM)
4	4 INCH (100MM)	6	6 INCH (150MM)					
ASME RATING						A		
A	150	B	300	C	600		D	150-600 (WAFER)
END CONNECTION						F		
F	RF	W	WAFER					
BODY MATERIAL						L		
W	WCC	M	CF3M					
PACKING TYPE						-		
-	BRAIDED CARBON PTFE							
TRIM						A		
A	TRIM STYLE A	B	TRIM STYLE B					
C	TRIM STYLE C	D	TRIM STYLE D					
E	TRIM STYLE E	F	TRIM STYLE F					
G	TRIM STYLE G	H	TRIM STYLE H					
BUSHINGS						C		
A	R30006	C	S44004	R	R30006 WITH O-RINGS		S	S44004 WITH O-RINGS
PAINT						-		
-	DFPS-01 (STANDARD)	2		DFPS-02 (SEVERE SERVICE)				
3	DFPS-03 (HIGH TEMPERATURE)							
O-RING MATERIAL						V		
-	VITON	K	KALREZ®					
FLOW DIRECTION						F		
F	FLOW TO OPEN	R	FLOW TO CLOSE					
CV FACTOR						1		
4	0.20	3	0.40	2	0.60		1	1.00

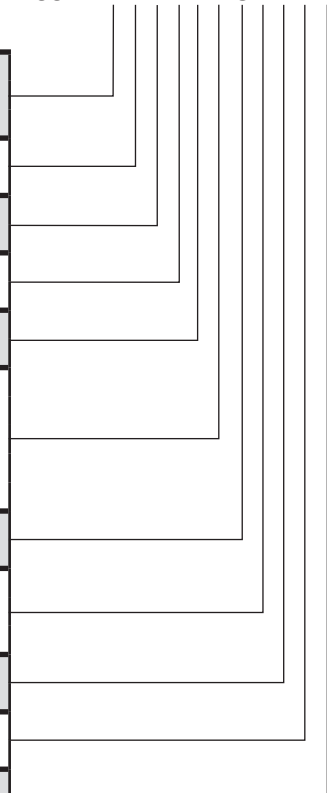

DF400V - - - - -

NOTE: DF400 Actuator Model Builder is located on Page 19.

Dyna-Flo Control Valve Services Ltd., a Business Unit of Curtiss-Wright Flow Control Corporation
Headquarters: 1911 66 Avenue, Edmonton, AB, T6P 1M5 Canada • Telephone: 1-866-396-2356 • Fax: 780-469-4035
www.dynaflo.com
Offices Worldwide: For a listing of our global sales network, visit our website at www.dynaflo.com/distributors

While this information is presented in good faith and believed to be accurate, Dyna-Flo Control Valve Services Ltd., division of Curtiss-Wright Flow Control Corporation, does not guarantee satisfactory results from reliance on such information. Nothing contained herein is to be construed as a warranty or guarantee, expressed or implied, regarding the performance, merchantability, fitness or any other matter with respect to the products, nor as a recommendation to use any product or process in conflict with any patent. Dyna-Flo Control Valve Services Ltd., division of Curtiss-Wright Flow Control Corporation, reserves the right, without notice, to alter or improve the designs or specifications of the products described herein.

