

# Model DF2000 Control Valve

## Operation, Parts, and Instruction Manual



**Figure 1** DF2000 Control Valve & DFC Actuator

### TABLE OF CONTENTS

<b>Introduction</b>	<b>2</b>	<b>Jam Style Packing - Figure 2</b>	<b>9</b>
<b>General</b>	<b>2</b>	<b>Body Reassembly</b>	<b>7</b>
<b>Scope</b>	<b>2</b>	Seat Ring Installation	7
<b>Specifications</b>	<b>3</b>	<b>Packing Box</b>	<b>7</b>
<b>Rated Inlet Pressure and Temperature - Table 1</b>	<b>3</b>	Bonnet Installation	7
<b>Valve Dimensions - Table 2</b>	<b>4</b>	<b>Lapping</b>	<b>7</b>
<b>Unpacking</b>	<b>4</b>	<b>Seat Leakage</b>	<b>8</b>
<b>Installation</b>	<b>4</b>	<b>Lapping Handle - Figure 3</b>	<b>8</b>
Packing Maintenance	4	<b>Torque Values - Table 3</b>	<b>9</b>
Air Piping	5	<b>Globe Body Assembly (NPT Connection) - Figure 4</b>	<b>9</b>
<b>Periodic Inspection</b>	<b>5</b>	<b>Angle Body Assembly (RF Connection) - Figure 5</b>	<b>9</b>
<b>Maintenance</b>	<b>5</b>	<b>Parts</b>	<b>10</b>
Body Disassembly	5	<b>Parts Kits - Table 4</b>	<b>12</b>
Bonnet Removal and Inspection	5	<b>Model Builder</b>	<b>16</b>
Seat Ring Removal and Inspection	6		
Packing Box	6		
Packing Types	6		



# Model DF2000 Control Valve

## Operation, Parts, and Instruction Manual

### NOTICE

These instructions are meant to be used with the Dyna-Flo DF2000 Technical Bulletin as they refer to Figures and Tables therein. If you do not have the Technical Bulletin, contact Dyna-Flo immediately, or visit [www.dynaflo.com](http://www.dynaflo.com)

Each control valve is factory checked. Check the calibration for the specific application, before a valve is put into service.

It is the intention of this document to provide users with an accurate guide for safe installation and maintenance of the DF2000 Control Valve. Revisions and updates are available at above mentioned website.

## INTRODUCTION

The Model DF2000 Control Valves are heavy duty globe style control valves used in all kinds of demanding oil and gas applications, from well head to gas plant and beyond.

The Model DF2000 control valves are post guided, single port valves that can be used for either throttling or on-off control of either liquids or gasses.

The actuator for the Model DF2000 valve is typically a Dyna-Flo model DFC or DFO linear actuator. These heavy duty actuators are spring return diaphragm style, and can be used with or without a valve positioner.

The Model DF2000 control valves are manufactured to a high level of quality specifications to ensure superior performance and customer satisfaction.

## GENERAL

**The following instructions are to be thoroughly reviewed and understood prior to installing, operating or performing maintenance on this equipment. Work on this equipment should be performed by experienced personnel. Throughout the manual, safety and caution notes appear and must be strictly followed, to prevent serious injury or equipment malfunction.**

## SCOPE

The control valve configuration and construction materials were selected to meet particular pressure, temperature, and process conditions. Some material combinations are limited in their pressure and temperature ranges. Do not apply any other conditions to the valve without first contacting your Dyna-Flo sales office.

This manual is written to be a practical and useful guide maintaining the Dyna-Flo DF2000 Control Valve.

### CAUTION

**To avoid personal injury or installation damage as a result of the sudden release of process pressure or the breaking of parts, do not install the valve assembly where service conditions could exceed the limits stated in this manual or on the equipment nameplates. Use government codes, accepted industry standards and good piping practices to select pressure-relieving equipment for protection of your installation. It is also important to wear the proper protective equipment when performing any installation or maintenance activity.**

# Model DF2000 Control Valve

## Operation, Parts, and Instruction Manual



### SPECIFICATIONS

#### Valve Size, Flange Ratings, and Connections

Size: 1" and 2" (Globe and Angle Body).  
Rating: ASME 150/300/600/900/1500/2500.  
Connections: RF / RTJ / NPT.

#### Rated Inlet Pressure and Temperature

Per ASME B16.34  
Also refer to Table 1.

#### Maximum Allowable Pressure Drops

(Refer to Tables 9 & 10 of the Sales Bulletin)

Flow-to-open: Capable of full rated pressure drops.  
Flow-to-close: For more information contact your Dyna-Flo Sales Office.

#### Material Temperature Capabilities

LCC body (standard): -50 to 450°F (-45 to 232°C).  
CF8M body: -150 to 700°F (-101 to 371°C).

#### Construction Materials

Refer to Figures 3 & 4 of the Sales Bulletin for valve diagram.  
Refer to Table 8 of the Sales Bulletin for construction materials.

#### Dimensions

Valve and Actuator assembly diagram - Refer to Figure 2 of the Sales Bulletin.  
Valve and Actuator assembly dimensions - Refer to Tables 3 - 7 of the Sales Bulletin.

#### Flow Direction

Typically up through seat ring and out past valve plug.

#### Flow Characteristic

Dyna-Form Equal Percent  
Dyna-Flute 1 Flute (Equal Percent)  
Dyna-Flute 3 Flute (Equal Percent)

#### Port, Yoke Boss Diameter, Stem Diameters, and Travel

Refer to Table 11 of the Sales Bulletin.

#### Valve Sizing Coefficients

For standard coefficients at maximum travel, refer to Tables 12 & 13 of the Sales Bulletin. For full list of coefficients refer to document P-CVSM.

#### Valve Body and Actuator

Approximate Weights - Refer to Table 2.

#### Options

- Trim in Tungsten Carbide.
- Anti-corrosion coating of internal body passage.
- Live loaded low emission packing.

For more information and other options contact your Dyna-Flo sales office.



# Model DF2000 Control Valve

## Operation, Parts, and Instruction Manual

<b>Rated Inlet Pressure and Temperature</b>						
Valve Size	Body Type	Class <sup>◊</sup>	Temperature		Maximum Pressure	
			°F	°C	Psi	Bar
1 and 2 Inch	NPT	3750* (1500 ASME)	100	38	3,750	259
			450	232	3,425	236
		6250* (2500 ASME) (2" Body Only)	100	38	6,250	431
			450	232	5,710	394
	Flanged	150 ASME	100	38	290	20
			450	232	185	13
		300 ASME	100	38	750	52
			450	232	685	47
		600 ASME	100	38	1,500	103
			450	232	1,370	94
		1500 ASME	100	38	3,750	259
			450	232	3,425	236
		2500 ASME (2" Body Only)	100	38	6,250	431
			450	232	5,710	394

\* Indicates Working Class Pressure (Psig)      ◊ Indicates Class or Cold Working Pressure Limit

<b>Port Size, Yoke Boss and Stem Diameter, Rated Travel Inch (mm)</b>							
Valve Size	Port Diameter Inch (mm)	Standard Inch (mm)			Optional Inch (mm)		
		Yoke Boss Diameter	Stem Diameter	Rated Travel	Yoke Boss Diameter	Stem Diameter	Rated Travel
1 Inch	1/4 (6.4)	2-1/8 (54.0)	3/8 (9.5)	3/4 (9.5)	2-13/16 (71.4)	1/2 (12.7)	3/4 (19.1)
	3/8 (9.5)						
	1/2 (12.7)						
	3/4 (19.1)						
2 Inch	1/4 (6.4)	2-13/16 (71.4)	1/2 (12.7)	3/4 (19.1)	3-9/16 (90.5)	3/4 (19.1)	3/4 (19.1)
	3/8 (9.5)						
	1/2 (12.7)						
	3/4 (19.1)						
	1 (25.4)						
	1-1/4 (31.8)						

# Model DF2000 Control Valve

## Operation, Parts, and Instruction Manual



### UNPACKING VALVE FROM SHIPPING CONTAINER

Check the packing list against materials received, while unpacking the valve. The Packing List describes valve and accessories in each shipping container.

When lifting the valve from shipping container, it is advisable to remove 2 actuator casing bolts, 180° apart, and temporarily replace them with eye bolts and nuts. Position the lifting straps through the eye bolts to avoid damage to the tubing and mounted accessories.

### INSTALLATION

Before installing the valve, clean dirt, welding chips, scale or other foreign material from the line.

Look for signs of gasket leakage through the line flanges. Make repairs, if required.

Check packing box bolting for proper tightness, stem leakage may be prevented by tightening the packing nuts. Reference Table 3 for packing nut torque specifications.

#### Packing Maintenance

##### CAUTION

---

**Do not over tighten packing! This can cause excessive packing wear and high stem friction that may impede movement!**

---

If the packing is leaking and tightening the packing flange does not stop the leak then it is recommended that you remove the valve from the line.

- 1 Install the valve with flow through the valve in the direction as indicated by the arrow cast on the valve body. The valve assembly may be installed in any position unless limited by vibration considerations.

##### NOTE

---

**The normal method of installation is with the actuator in vertical position above the valve body. In some non-vertical applications the actuator may need to be supported.**

---

##### WARNING

---

**Keep hands, hair and clothing away from all moving parts when operating the valve! Serious injury can result from failure to do so!**

---

- 2 When possible, stroke the valve and check for smooth operation through the full-stroke. Unsteady valve stem movement could be an indication of an internal problem.

#### Air Piping

The actuators are designed to accept 1/4" NPT connection. Use 3/8" OD tubing (or equivalent) for all air lines. All connections must be free of leaks.

##### CAUTION

---

**Do not exceed supply pressure indicated on serial plate located on the yoke of the actuator.**

---



# Model DF2000 Control Valve

## Operation, Parts, and Instruction Manual

### PERIODIC INSPECTION

#### CAUTION

**Use safe work practices and lock out procedures when isolating valves and actuators! Always be aware of flammable instrument gas!**

- 1** Avoid personal injury from sudden release of process pressure! Before performing any maintenance operation:
  - A** Disconnect any power supply media lines providing air / gas pressure, electric power, or a control signal to the actuator. Ensure the actuator cannot suddenly operate the valve.
  - B** Isolate the valve from process pressure with bypass valves or completely shut off the process. Relieve process pressure, and drain the process fluid from the up and down stream of the valve.
  - C** Vent the pneumatic actuator loading pressure and relieve any actuator spring preload.
  - D** Use Safety lock-out procedures to be sure that the above provisions stay in effect while you complete the work on your equipment.
- 2** Check for process fluid leakage to the atmosphere through the body to bonnet joint and (if equipped) any NPT connection.
- 3** Examine the valve for damage caused by corrosive fumes or process drippings.
- 4** Clean the valve and repaint areas of severe oxidation.
- 5** Make sure positioner linkage (if equipped) and stem clamp are securely fastened. If the stem clamp is loose, check plug thread engagement and retighten. Refer to the Dyna-Flo Model DFC, or DFO Manual for detailed instructions.
- 6** Ensure all accessories, mounting brackets and fasteners are secure.
- 7** Clean any dirt and foreign material from the plug stem.

### MAINTENANCE

#### Body Disassembly

- 1** Vent the pneumatic actuator loading pressure and relieve any actuator spring preload.

#### CAUTION

**The body can be serviced in-line, after all process pressure and fluid are released. Remove if convenient. If the valve is to be serviced out of line, it is important that the body be firmly held in a clamping device. Serious injury can result from failure to do so!**

- 2** Once the body is secured, and any actuator spring preload relieved, remove the stem connector (Key 18) joining the valve stem to the actuator stem.

**ALL Key references to follow are from Figure 4.**

- 3** With a hammer and heavy chisel, strike the actuator yoke lock nut (Key 14) in a counter clockwise direction to loosen it, and remove the actuator. Actuator removal may require a second person, or the use of a hoist.

#### Bonnet Removal and Inspection

- 1** Remove the packing nuts (Key 12), note any corrosion or roughness in the threads.
- 2** Remove the packing flange (Key 10). Note any corrosion and remove the stem wiper (Key 11) and packing follower (Key 9).
- 3** DF2000 bonnets are factory tightened as show in Table 3. A large pipe wrench is commonly used to remove the bonnet. Once the bonnet is loosened it should move freely by hand. If the bonnet does not move freely be cautious of a build up of process pressure. Once the bonnet is disengaged from the body, carefully remove with the plug and stem still attached.
- 4** Inspect the bonnet threads in the body for damage. Minor galling, or corrosion may require sandblasting.
- 5** The bonnet gasket (Key 3) may come out with the bonnet assembly. If not, carefully remove the bonnet gasket from the body, avoid scratching the gasket surface.

# Model DF2000 Control Valve

## Operation, Parts, and Instruction Manual



### MAINTENANCE (Continued)

#### Seat Ring Removal and Inspection

- 1 A 1-3/8" deep socket (non-impact type) with a 3/4" drive (for the 1" valve) and a 1-13/16" deep socket (non-impact type) with a 3/4" drive (for the 2" valve) are required. A standard mechanic's "Pick Set" will help with the seat ring gasket removal (Key 15).
- 2 Wipe the gasket sealing surface of the body and the bonnet and inspect for signs of leakage, corrosion, or other marks. Refer to the section on wear limits for guidance if a concern arises.
- 3 Inspect the seat ring threads in the body for damage. Major galling, or corrosion may require sandblasting of the body to restore "as new" condition. Also, inspect the threads on the seat ring for signs of galling or corrosion.
- 4 Inspect the plug seating area, and the gasket surface of the seat ring for damage or marks of any kind. Deep marks are cause for replacement as the hard faced seat ring is difficult to recondition outside of the factory.

#### Packing Box

- 1 With the bonnet removed from the body, pull the plug and stem assembly (Key 17) out of the bonnet (Key 2). The plug and stem assembly can then be reinserted to push the packing [packing box ring (Key 5), the bottom packing set (Key 6), packing spacer (Key 7), and the top packing set (Key 8)] out of the packing box.
- 2 Retain the packing box ring, and spacer for use in the reassembly of the valve.
- 3 With all the parts removed from the bonnet, clean and inspect all gasket and packing seating surfaces. Also, inspect bushing (Key 2a) for damage. Check threads for galling or corrosion.

#### Packing Types

The DF2000 is standard equipped with jam style packing, as shown in Figure 2.

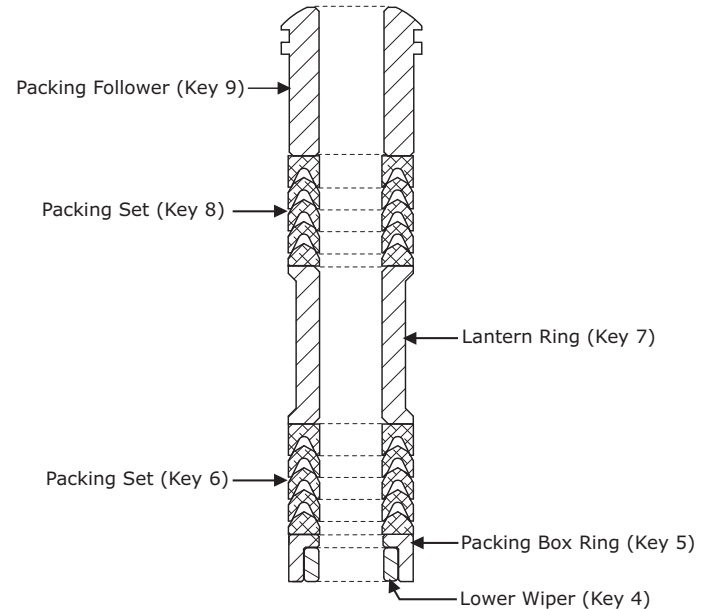

\* Key Numbers Correspond to Figure 4 Keys

**Figure 2** Jam Style Packing



# Model DF2000 Control Valve

## Operation, Parts, and Instruction Manual

### BODY REASSEMBLY

#### Seat Ring Installation

- 1 Clean and inspect the seat ring threads, and the threads in the body. A 1-3/8" deep socket (non-impact) with a 3/4" drive (for the 1" valve) and a 1-13/16" deep socket (non-impact) with a 3/4" drive (for the 2" valve) is required for seat ring (Key 16) installation. Coat both sides of the seat ring gasket (Key 15) with Nickel based anti-seize compound, and place the gasket carefully in the body. Completely coat the seat ring threads with Nickel based anti-seize compound, and place the seat ring into a clean body. Dry threads could prevent proper seating of the seat ring against the gasket, allowing leakage.
- 2 Carefully use the deep socket and drive bar to thread the seat ring into place. The seat ring should turn smoothly into place. Any significant resistance should be investigated, and corrected to ensure proper assembly. Torque the seat ring as per torque values stated in Table 3.

#### PACKING BOX

- 1 Prepare the components for reassembling the packing box by using the appropriate packing lubricant on the lower wiper (Key 4) for the bottom of the packing box ring (Key 5). Carefully place the assembled packing box ring (Key 4 & 5) in place, in the bottom of a clean packing box.
- 2 Lubricate the "V" of each PTFE packing ring (Key 6) and stack in a set as shown in Figure 2. There will be 2 sets of packing rings.
- 3 Insert the bottom packing set with the open end of the "V" pointing down, over the valve stem. Avoid sliding the packing over any sharp edges that could damage the packing. Insert the packing spacer (Key 7), and then the top set of packing (Key 8) with the "V" again pointing down.

#### Bonnet Installation

- 1 Coat the large diameter guide section of the valve plug and stem assembly (Key 17) with mechanical assembly grease, and carefully place the plug into the seat ring (Key 16).
- 2 Coat both sides of the bonnet gasket (Key 3) and bonnet threads with Nickel based anti-seize compound, and place the gasket carefully in a clean body.

- 3 Lower the bonnet (Key 2) carefully over the stem and hand tighten into place.
- 4 Torque the bonnet to the valve size appropriate to the torque value listed in Table 3. Insert the packing follower (Key 9) over the stem, into the packing box. Slide the stem wiper (Key 11) over the stem, down to the top of the packing follower (Key 9).
- 5 Place the packing flange (Key 10) over the studs (Key 13) and stem, with the beveled stem hole side facing the packing follower (Key 9).
- 6 Lubricate the exposed portion of the packing flange stud (Key 13) with Nickel based anti-seize compound and install the packing flange nuts (Key 12), with the material guide markings facing up. Tighten the nuts to the appropriate valve size torque value as indicated in Table 3.

#### LAPPING

If the seat ring and plug seating surface are in good condition, properly performed seat lapping can restore valve seat tightness.

- 1 Clean the seating surface of the plug and seat ring with a 400-600 grit emery cloth.
- 2 Install the seat ring (Key 16) using the Body Reassembly instructions.
- 3 Apply 400-600 grit lapping compound to the seating area of the plug (Key 17).
- 4 Insert the plug and stem (Key 17) into the bonnet (Key 2), without packing.
- 5 Place bonnet (Key 2) and plug (Key 17) into the body (Key 1), and hand tighten bonnet.
- 6 Insert the packing box follower (Key 9) into the bonnet to help align the stem.
- 7 See Figure 3 on how to use 2 stem nuts and two 9/16" box end wrenches as a handle to lap the seat.

#### CAUTION

**If you hear a squeaking noise during this operation, the seating area has become dry of lapping compound and galling of the surfaces could result.**



# Model DF2000 Control Valve

## Operation, Parts, and Instruction Manual



### LAPPING (Continued)

- 8 While holding the wrenches and **applying light pressure**, make a 1/8 turn clockwise, and then a 1/8 turn counter clockwise.
- 9 After 3 cycles of turning the plug and stem, lift the stem to pull lapping compound into the seating area.
- 10 Repeat this process for 1 minute.
- 11 Remove the bonnet, plug and stem from the body.

12 Wipe the seating areas of the plug and seat ring.

13 A fine "lap line" should be visible on the seating surface of the seat ring and valve plug. This should result in sound mating surfaces.

#### NOTE

**If you do not see a full "lap line", evaluate if a second round of lapping can remove the deviation. Deep marks will require machining.**

### SEAT LEAKAGE

The DF2000 is a metal seated valve and will leak a small amount under normal conditions. The leakage rate of the DF2000 allows a Class IV leakage rating to be applied under ASME / FCI 70-2. The standard also requires testing of the valve at the service pressure drop, or 50 psig (3.45 Bar), whichever is lower. Each DF2000 is shop tested to meet the allowable leakage rate that is a percentage of the port size maximum flow rate.

#### NOTE

**If you need "tight shut-off" at a high pressure drop, please consult your Dyna-Flo sales office.**



**Figure 3** *Lapping Handle*



# Model DF2000 Control Valve

## Operation, Parts, and Instruction Manual

Table 3

Body Size	Packing Box Nuts (Key 5)		Seat Ring (Key 16) lbf-in. (N·m)	Bonnet Hex (Key 2) lbf-in. (N·m)
	Minimum lbf-in. (N·m)	Maximum lbf-in. (N·m)		
1	40 (4.4)	50 (5.6)	302 (410)	804 (1,090 ) (2-5/8" hex)
2	70 (7.8)	100 (11.1)	524 (710)	1,497 (2,030) (3-1/4" hex)

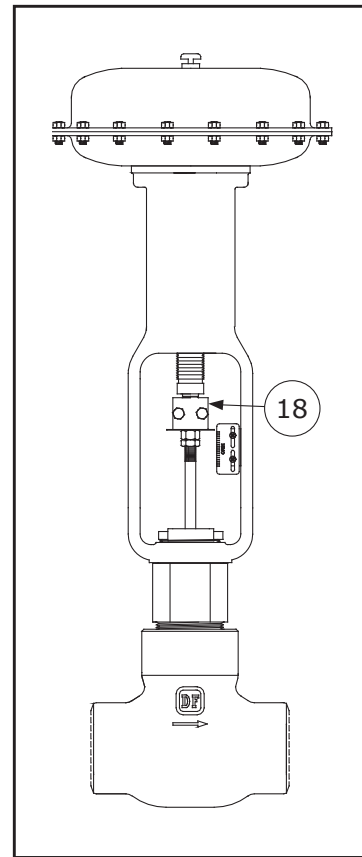
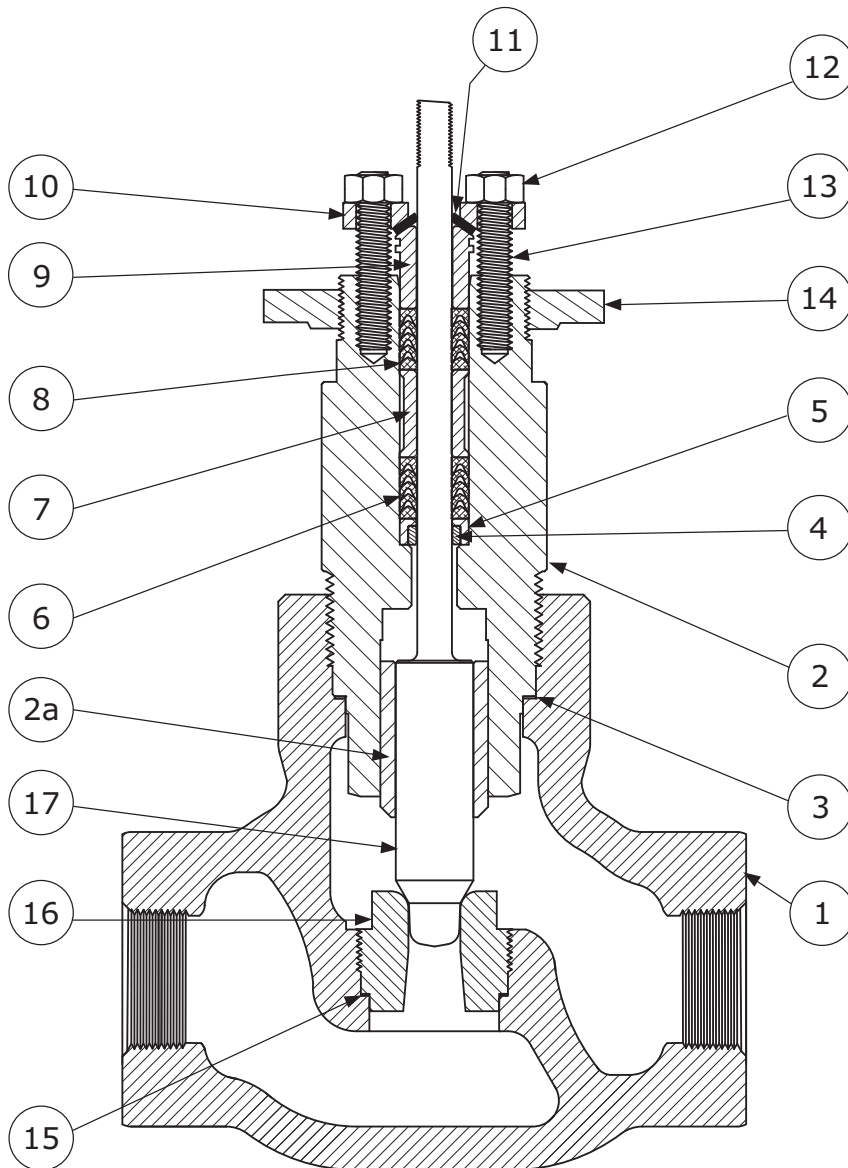

**Figure 4**  
Typical DF2000 Assembly  
with NPT Connections

# Model DF2000 Control Valve

## Operation, Parts, and Instruction Manual

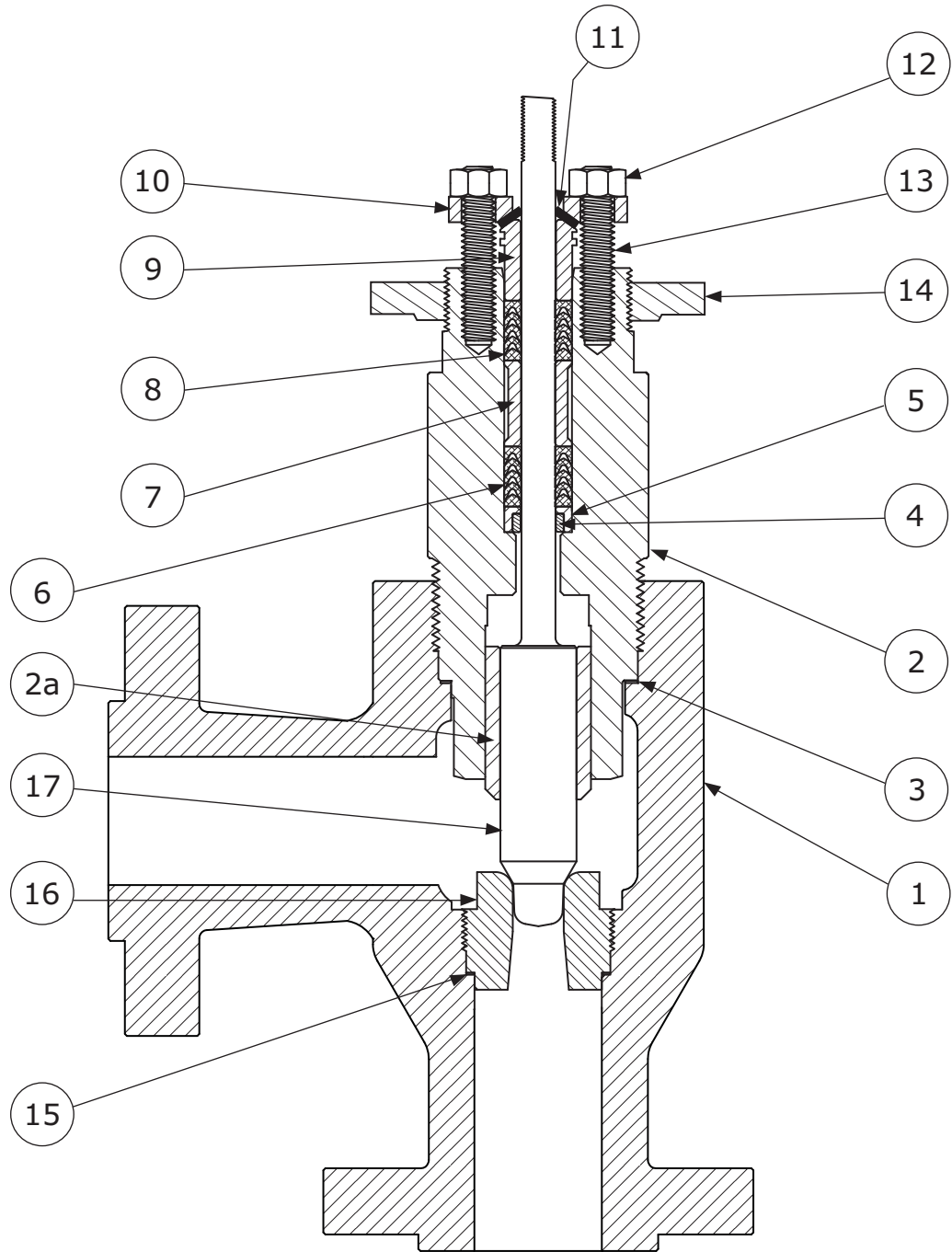

**Figure 5** Typical DF2000 Angle Body Assembly with Flanged Connections



# Model DF2000 Control Valve

## Operation, Parts, and Instruction Manual

### Parts

Key	Description	Part Number
<b>1</b>	<b>Body, Globe &amp; Angle</b>	
	LCC	
	1 Inch	Contact Factory
	2 Inch	Contact Factory
<b>2</b>	<b>Bonnet / Bushing Assembly</b>	
	LCC	
	1 Inch	1DF2000B01D
	2 Inch	2DF2000B01D
<b>2a</b>	<b>Bushing</b>	
	S17400 DH1150	
	1 Inch	Included with Key 2
<b>3</b>	<b>Bonnet Gasket</b>	
	S30400	
	1 Inch	1B19823604D
	2 Inch	1B19843604D
<b>4</b>	<b>Lower Wiper</b>	
	PTFE	
	1 Inch	1J87210699D
	2 Inch	1J87220699D
<b>5</b>	<b>Packing Box Ring</b>	
	S31600/S31603 Dual Grade	
	1 Inch	1J87313507D
	2 Inch	1J87323507D
<b>6 &amp; 8</b>	<b>Packing Set</b>	
	PTFE	
	1 Inch	1R2900010DD
	2 Inch	1R2902010DD
<b>7</b>	<b>Packing Spacer</b>	
	S31600	
	1 Inch	1F36413507D
	2 Inch	1J96233507D
<b>9</b>	<b>Packing Follower</b>	
	S31600/S31603 Dual Grade	
	1 Inch	1E94393507D
	2 Inch	1E94433507D
<b>10</b>	<b>Packing Flange</b>	
	Plated Steel	
	1 Inch	1E94372410D
	2 Inch	1E94422307D

Key	Description	Part Number
<b>11</b>	<b>Outboard Seal Carrier</b>	
	Felt	
	1 Inch	1J87260633D
<b>12</b>	<b>Packing Nut</b>	
	8M (2 Required)	
	1 Inch	1E94403525D
<b>13</b>	<b>Packing Stud</b>	
	B8M (2 Required)	
	1 Inch	1E94413522D
<b>14</b>	<b>Yoke Nut</b>	
	Zinc Plated Steel	
	1 Inch	1E79302306D
<b>15</b>	<b>Seat Ring Gasket</b>	
	S30400	
	1 Inch	1B19863604D
<b>16</b>	<b>Seat Ring</b> (See Table 4)	
	-S31600/S31603 Dual Grade / Alloy 6	
	<i>1 Inch Valve</i>	
	1/4 Inch Port	2B5097X001D
	3/8 Inch Port	2B5098X001D
	1/2 Inch Port	2B5099X001D
	3/4 Inch Port	2B5100X001D
	<i>2 Inch Valve</i>	
	1/4 Inch Port	2B5106X001D
	3/8 Inch Port	2B5107X001D
	1/2 Inch Port	2B5108X001D
	3/4 Inch Port	2B5109X001D
	1 Inch Port	2B5110X001D
	1-1/4 Inch Port	2K1801X001D
	-S17400 DH1150	
	<i>1 Inch Valve</i>	
1/4 Inch Port	2B5097X174D	
3/8 Inch Port	2B5098X174D	
1/2 Inch Port	2B5099X174D	
3/4 Inch Port	2B5100X174D	

# Model DF2000 Control Valve

## Operation, Parts, and Instruction Manual



### Parts

Key	Description	Part Number
<b>16</b>	<b>Seat Ring</b> (Continued)	
	-S17400 DH1150	
	<i>2 Inch Valve</i>	
	1/4 Inch Port	2B5106X174D
	3/8 Inch Port	2B5107X174D
	1/2 Inch Port	2B5108X174D
	3/4 Inch Port	2B5109X174D
	1 Inch Port	2B5110X174D
	1-1/4 Inch Port	2K1801X174D
<b>17</b>	<b>Plug &amp; Stem Assembly</b> (See Table 4)	
	<b>Equal Percent</b>	
	-S31600/S31603 Dual Grade / Alloy 6 & S20910	
	<i>1 Inch Valve</i>	
	1/4 Inch Port	2F1388X004D
	3/8 Inch Port	2F1389X003D
	1/2 Inch Port	2F1390X003D
	3/4 Inch Port	2F1391X003D
	<i>2 Inch Valve</i>	
	1/4 Inch Port	2F1427X002D
	3/8 Inch Port	2F1428X002D
	1/2 Inch Port	2F1429X002D
	3/4 Inch Port	2F1430X002D
	1 Inch Port	2F1431X002D
	1-1/4 Inch Port	2L5331X003D
	-S17400 DH1150 & S20910	
	<i>1 Inch Valve</i>	
	1/4 Inch Port	2F1388X174D
	3/8 Inch Port	2F1389X174D
	1/2 Inch Port	2F1390X174D
	3/4 Inch Port	2F1391X174D
	<i>2 Inch Valve</i>	
	1/4 Inch Port	2F1427X174D
	3/8 Inch Port	2F1428X174D
	1/2 Inch Port	SF1429X174D
	3/4 Inch Port	2F1430X174D
	1 Inch Port	2F1431X174D
	1-1/4 Inch Port	2L5331X174D
	<b>1 Flute Dyna-Flute</b>	
	-S31600/S31603 Dual Grade / Alloy 6 & S20910	
	<i>1 Inch Valve</i>	
	1/4 Inch Port	Contact Factory

Key	Description	Part Number
	<i>2 Inch Valve</i>	
	1/4 Inch Port	Contact Factory
	-S17400 DH1150 & S20910	
	<i>1 Inch Valve</i>	
	1/4 Inch Port	Contact Factory
	<i>2 Inch Valve</i>	
	1/4 Inch Port	Contact Factory
	-Tungsten Carbide & S20910	
	<i>1 Inch Valve</i>	
	1/4 Inch Port	Contact Factory
	<i>2 Inch Valve</i>	
	1/4 Inch Port	Contact Factory
	<b>3 Flute Dyna-Flute</b>	
	-S31600/S31603 Dual Grade / Alloy 6 & S20910	
	<i>1 Inch Valve</i>	
	1/4 Inch Port	Contact Factory
	<i>2 Inch Valve</i>	
	1/4 Inch Port	Contact Factory
	-S17400 DH1150 & S20910	
	<i>1 Inch Valve</i>	
	1/4 Inch Port	Contact Factory
	<i>2 Inch Valve</i>	
	1/4 Inch Port	Contact Factory
	-Tungsten Carbide & S20910	
	<i>1 Inch Valve</i>	
	1/4 Inch Port	Contact Factory
	<i>2 Inch Valve</i>	
	1/4 Inch Port	Contact Factory

### Parts Ordering

Whenever corresponding with Dyna-Flo about a Model DF2000 control valve, refer to the actuator nameplate or the neck of the valve body for the unit serial number. Please order by the complete part number (as given in the Parts List) of each part required.



# Model DF2000 Control Valve

## Operation, Parts, and Instruction Manual

**Table 4**

Description	Part Number	
	1"	2"
S31600/S31603 Dual Grade / Alloy 6 Plug (S20910 Stem) and Seat Ring, Double Packing Felt Wiper and Gaskets		
1/4 Inch Port Diameter	RDXCNTRM11D	RDXCNTRM21D
3/8 Inch Port Diameter	RDXCNTRM12D	RDXCNTRM22D
1/2 Inch Port Diameter	RDXCNTRM13D	RDXCNTRM23D
3/4 Inch Port Diameter	RDXCNTRM14D	RDXCNTRM24D
1 Inch Port Diameter	N/A	RDXCNTRM25D
1-1/4 Inch Port Diameter	N/A	RDXCNTRM26D
S31600/S31603 Dual Grade / Tungsten Carbide Plug (S20910 Stem) and Seat Ring		
1/4 Inch Port Diameter	TDX1000007D (3/8 Inch Stem)	TDX2000007D (1/2 Inch Stem)
3/8 Inch Port Diameter	TDX1000008D (3/8 Inch Stem)	TDX2000008D (1/2 Inch Stem)
1/2 Inch Port Diameter	TDX1000009D (3/8 Inch Stem)	TDX2000009D (1/2 Inch Stem)
3/4 Inch Port Diameter	TDX1000010D (3/8 Inch Stem)	TDX2000010D (1/2 Inch Stem)
1 Inch Port Diameter	N/A	TDX2000011D (1/2 Inch Stem)
1-1/4 Inch Port Diameter	N/A	TDX2000012D (1/2 Inch Stem)
1/2 Inch Port Diameter	N/A	TDX2000049D (3/4 Inch Stem)
3/4 Inch Port Diameter	N/A	TDX2000040D (3/4 Inch Stem)
1 Inch Port Diameter	N/A	TDX2000043D (3/4 Inch Stem)
1-1/4 Inch Port Diameter	N/A	TDX2000042D (3/4 Inch Stem)
Bonnet Gasket, Seat Ring Gasket, Packing		
Gasket Set & Packing - NACE	RDX0000CN1D	RDX0000CN2D

# Model DF2000 Control Valve

## Operation, Parts, and Instruction Manual



### ***Our Commitment to Quality***

Dyna-Flo is committed to continuous improvement. While all efforts have been made to ensure the accuracy of the content in this document, modifications or improvements to the information, specifications, and designs may occur at any time without notice. This document was published for informational purposes only, and does not express or imply suitability, a warranty, or guarantee regarding the products or services described herein or their use or applicability.

Neither Dyna-Flo Control Valve Services Ltd., nor any of their affiliated entities assumes responsibility for the selection, use and maintenance of any product. Responsibility for selection, use and maintenance of any product remains with the purchaser and end-user.



# Model DF2000 Control Valve

## MODEL NUMBERING SYSTEM

**SAMPLE PART NUMBER: DF2000-2AFL-S2J2-E4**

<b>BODY STYLE</b>					<b>-</b>	
-	GLOBE	A	ANGLE			
<b>VALVE SIZE</b>					<b>2</b>	
1	1 INCH	2	2 INCH			
<b>ASME RATING</b>					<b>A</b>	
A	150	B	300	C		600
D	900 / 1,500					
F	2,500	K	3" X 2" 150	H		3" X 2" 300
I	3" X 2" 600					
J	3" X 2" 900	G	3" X 2" 1,500	M		3" X 2" 2,500
Q	4" X 2" 150					
P	4" X 2" 300	L	4" X 2" 600	R	4" X 2" 900	
S	4" X 2" 1,500					
T	4" X 2" 2,500	E	3,750 PSI CWP (NPT)	N	6,250 PSI CWP (NPT)	
<b>END CONNECTION</b>					<b>F</b>	
F	RF	J	RTJ	N	NPT	
<b>BODY MATERIAL</b>					<b>L</b>	
L	LCC	M	CF8M			
<b>TRIM</b>					<b>S</b>	
S	S31600 / ALLOY 6	T	S31600 / TUNGSTEN CARBIDE			
<b>PORT SIZE</b>					<b>2</b>	
2	1/4"	3	3/8"	4	1/2"	
6	3/4"					
8	1"	1	1-1/4"			
<b>PACKING STYLE</b>					<b>J</b>	
J	DOUBLE PTFE V-RING (PRESSURE)		L		LIVE LOADED PTFE (PRESSURE)	
V	DOUBLE PTFE V-RING (VACUUM)		T		LIVE LOADED GRAPHITE (PRESSURE)	
R	DOUBLE PTFE V-RING (VACUUM / PRESSURE)		G		SINGLE GRAPHITE (PRESSURE)	
<b>YOKE BOSS SIZE</b>					<b>2</b>	
1	2-1/8" (3/8" STEM)	2	2-13/16" (1/2" STEM)	3	3-9/16" (3/4" STEM)	
<b>PAINT</b>					<b>-</b>	
-	DFPS-01 (STANDARD)		2		DFPS-02 (SEVERE SERVICE)	
3	DFPS-03 (HIGH TEMPERATURE)					
<b>CHARACTERISTIC</b>					<b>E</b>	
E	DYNA-FORM (EQUAL PERCENT) - FLOW UP					
F	DYNA-FLUTE 1 FLUTE (EQUAL PERCENT) - FLOW UP					
T	DYNA-FLUTE 3 FLUTE (EQUAL PERCENT) - FLOW UP					
D	DYNA-FORM (EQUAL PERCENT) - FLOW DOWN (ANGLE VALVE ONLY)					
1	DYNA-FLUTE 1 FLUTE (EQUAL PERCENT) - FLOW DOWN (ANGLE VALVE ONLY)					
3	DYNA-FLUTE 3 FLUTE (EQUAL PERCENT) - FLOW DOWN (ANGLE VALVE ONLY)					
<b>SHUT-OFF CLASS</b>					<b>4</b>	
4	CLASS IV	5	CLASS V			

**DF2000**